

Egismos *DATASHEET*

650nm Compact Laser Diode Modules Key features

Visible light $\lambda = 650\text{nm}$
Output powers $<1\text{mW}$, $<5\text{mW}$
Dimension: $8\text{mm} \times 17\text{mm}$
High reliability

Applications

Industrial alignment
Patient positioning

Laser Diode Solutions

The 650nm Compact Laser Diode Modules produce an elliptical, collimated output beam with output powers of $<1\text{mW}$ or $<5\text{mW}$. Operating voltage is from 2.6V to 6V DC at an operating current of 25~30mA typ ($<1\text{mW}$) or 50mA typ. ($<5\text{mW}$). Beam divergence is $<1\text{mrad}$ and operating temperature range is -10°C to $+90^\circ\text{C}$.

The modules consist of a brass housing, laser diode, drive circuit and adjustable collimating/focusing lens.

Electrical connections are made via external flying leads. The lens may be adjusted to produce either a collimated beam or focused spot.

The compact design has made S83650/H83650 series elliptical beam laser diode modules suitable for general purpose OEM application.

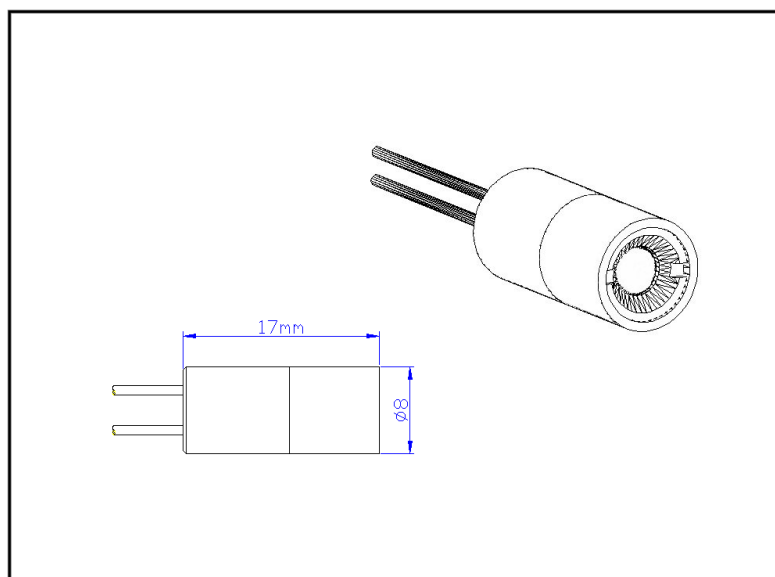

Egismos

<http://www.egismos.com>
TEL: +1-888-3481454
FAX: +1-604-4339864
E-Mail: sales@egismos.com

Egismos *DATASHEET*

Specifications (typical @ $t_c = 25^\circ\text{C}$)

Item.	symbol	S836501D/R, S836505D/R	H836501D/R, H836505D/R
Mode		CW	CW
Wavelength	λ	650nm	650nm
Laser Pattern		Dot/Round	Dot/Round
Dimeter x Length	$\Phi \times L$	8 x 17 mm	8 x 17 mm
Output Power	P_o	<1mW, <5mW	0.9mW \pm <10%, 3.2mW \pm <10% min. < 5%
Power Stability		< 10%	< 2%
Collimated Beam Size		<8x12mm at 10m	< 10mm round at 10m min. < 8mm at 10m
Collimated Beam Divergence		<1mrad	<0.2mrad min. < 0.1mrad
Operating Voltage(DC)	V_o	2.6-6.0V	2.6-6.0V
CW Operating Current	I_o	25~35mA typ., 50mA max.	25~35mA typ., 50mA max.
Operating Temperature	T_o	-10 $^\circ\text{C}$ to + 50 $^\circ\text{C}$	-10 $^\circ\text{C}$ to +70 $^\circ\text{C}$ or Higher max. to +90 $^\circ\text{C}$
Storage Temperature		-40 $^\circ\text{C}$ to + 85 $^\circ\text{C}$	-40 $^\circ\text{C}$ to + 120 $^\circ\text{C}$
Bore Sight		--	<12mm/m min. < 5mm/m
Houseing Material		Brass/Aluminum	Brass/Aluminum
Mean time to failure(MTTF)		>10,000 hrs	>10,000 hrs



Laser Safety

The light emitted from these devices has been set in accordance with IEC60825. However, staring into the beam, whether directly or indirectly, must be avoided. IEC60825 classifies laser products into three different categories depending on light emitted, wavelength and eye safety.

CLASS II

"Caution", visible laser light less than 1.0mW. Considered eye safe, normal exposure to this type of beam will not cause permanent damage to the retina.

CLASS III R

"Danger", visible laser light between 1.0mW and 5.0mW. Considered eye safe with caution. Focusing of this light into the eye could cause some damage.

CLASS III B

"Danger", infrared (IR), and high power visible lasers considered dangerous to the retina if exposed. NB: It is important to note that while complying with the above classifications, unless otherwise stated, our laser diode products are not certified and are designed solely for use in OEM products. The way in which the device is used in the final product may alter its original design classification, and it is the responsibility of the OEM to ensure compliance with the relevant standards.



<http://www.egismos.com>
 TEL: +1-888-3481454
 FAX: +1-604-4339864
 E-Mail: sales@eGismos.com